

Series: Swings

Item no.: 1045

Date: 16.09.2018

Agegroup: 3+

Mounting time: 5hours

Security area: 26,5m2

Requires surfacing: Yes

Fall height: 150 cm

Total weight: 320kg

Largest single part: 350cm Weight, largest part: 60 kg

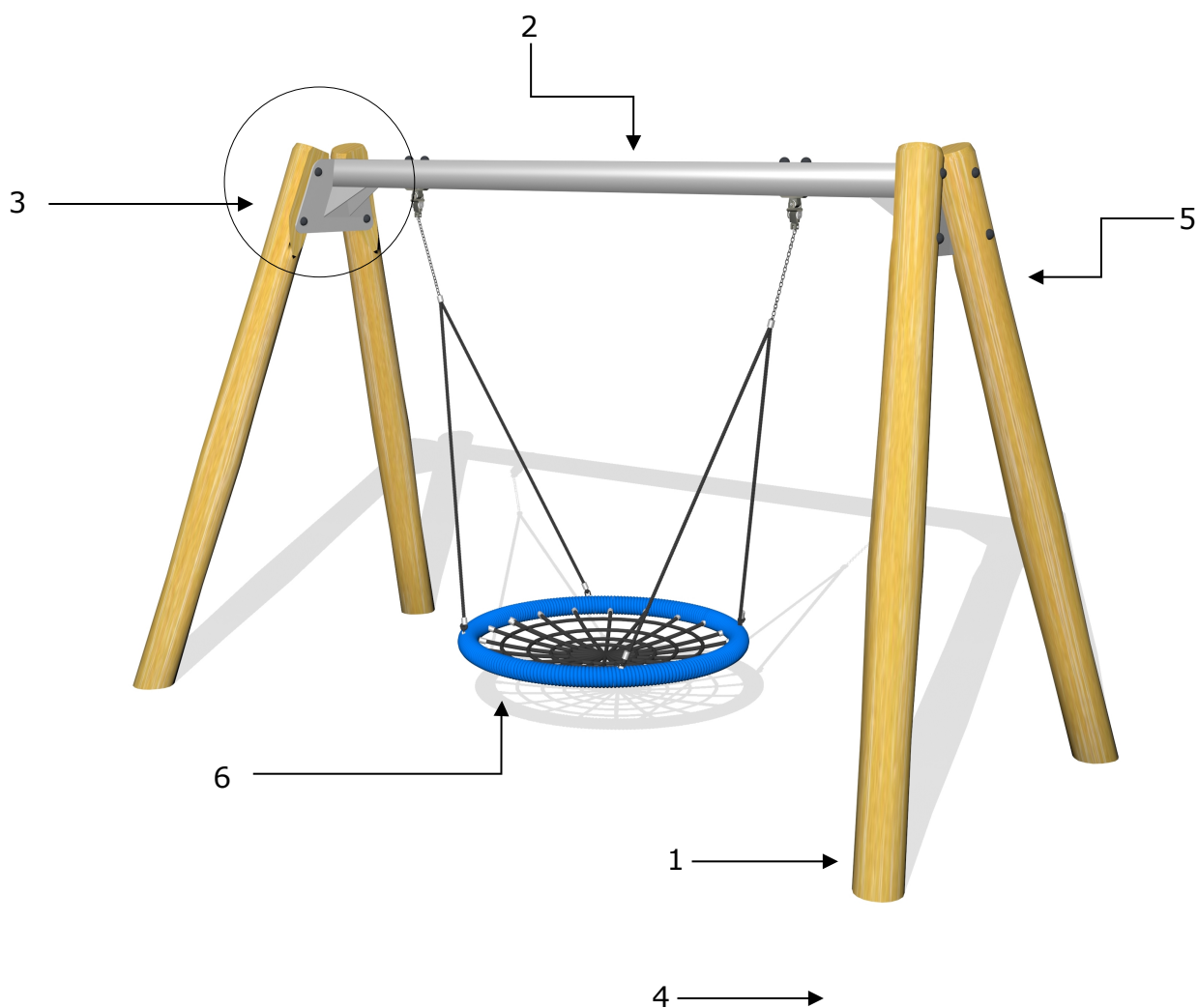

Item list:

No.:	Item no.:	Description	Dimension	Amount
1	ST 360	Robinia post	Ø14-16 L=360cm	4
2	GVA314 S	Swing steel crossbar, with mounting plates	L=314cm	1
3	MPG	Mounting principle	See drawing MPG	2
4	FD F2	Foundation ST	See drawing FD F1	4
5	PS	Productionsign	See drawing PS	1
6	KG120	Bird nest swing Ø120, incl. chain / shackle		1

Series: Swings

Item no.: 1045

Date: 16.09.2018

Agegroup: 3+

Mounting time: 5hours

Security area: 26,5m2

Requires surfacing: Yes



Fall height: 150 cm





Total weight: 320kg

Largest single part: 350cm Weight, largest part: 60 kg

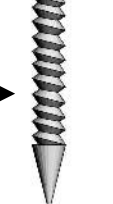
Plug → 

Plug → 

16 mm washer → 
Nut house → 
French screw, 12X90 → 

16 mm threaded rod, with welded nut → 
16 mm washer → 
Nut house → 

Nut house → 

16 mm washer → 

16 mm nut → 

Plug → 

French screw, 12X90 predrilled with Ø10



Assembly principle MPG

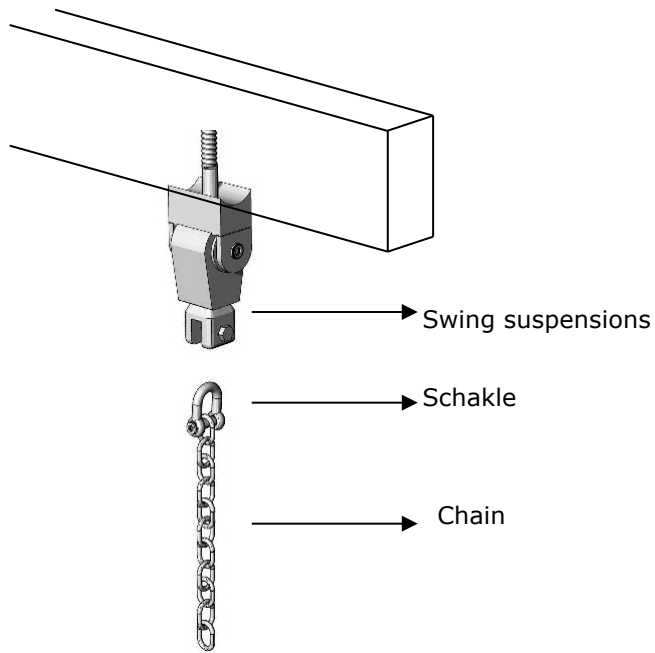

Foundation, FD F2

