

1013

Robinia stolper med taifun redegynge/robinia posts with taifun nets swing

Datablad / data sheet

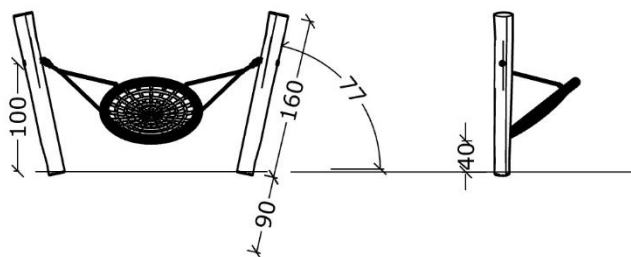
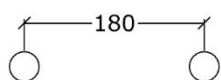
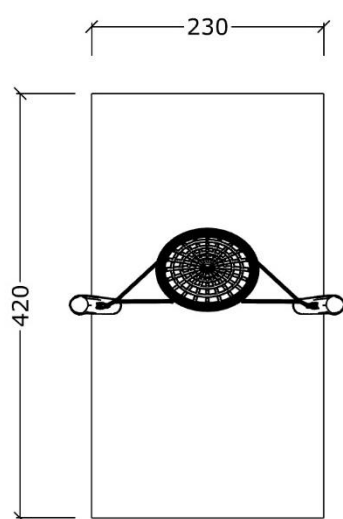

Serie: Gynger

Vare nr.: 1013

Dato: 07.08.2020

Aldersgruppe: 1+

Kræver faldunderlag: Nej

Sikkerhedsareal: 23 m²

Faldhøjde: 40 cm

Monteringstid: 4 timer

Antal montører: 2

Samlet vægt: 90 kg

Største enkelt del: 250 cm

Vægt største enkelt del: 40 kg

Kg beton pr hul: 40 kg

Forboret: Yes

Leveres samlet: Delvist

Handicap venligt: Ja



Serie: Swing

Item no.: 1013

Date: 07-08.2020

Age group: 1+

Demands fall underlay: No

Security area: 23 m²

Fall height: 40 cm

Mounting time: 4 hour

Numbers of installers: 2

Total weight: 90 kg

Largest part: 240 cm

Weight, largest part: 40 kg

Kg of concrete per hole: 40 kg

Predrilled: Yes

Delivered assembled: Partly

Disability access: Yes

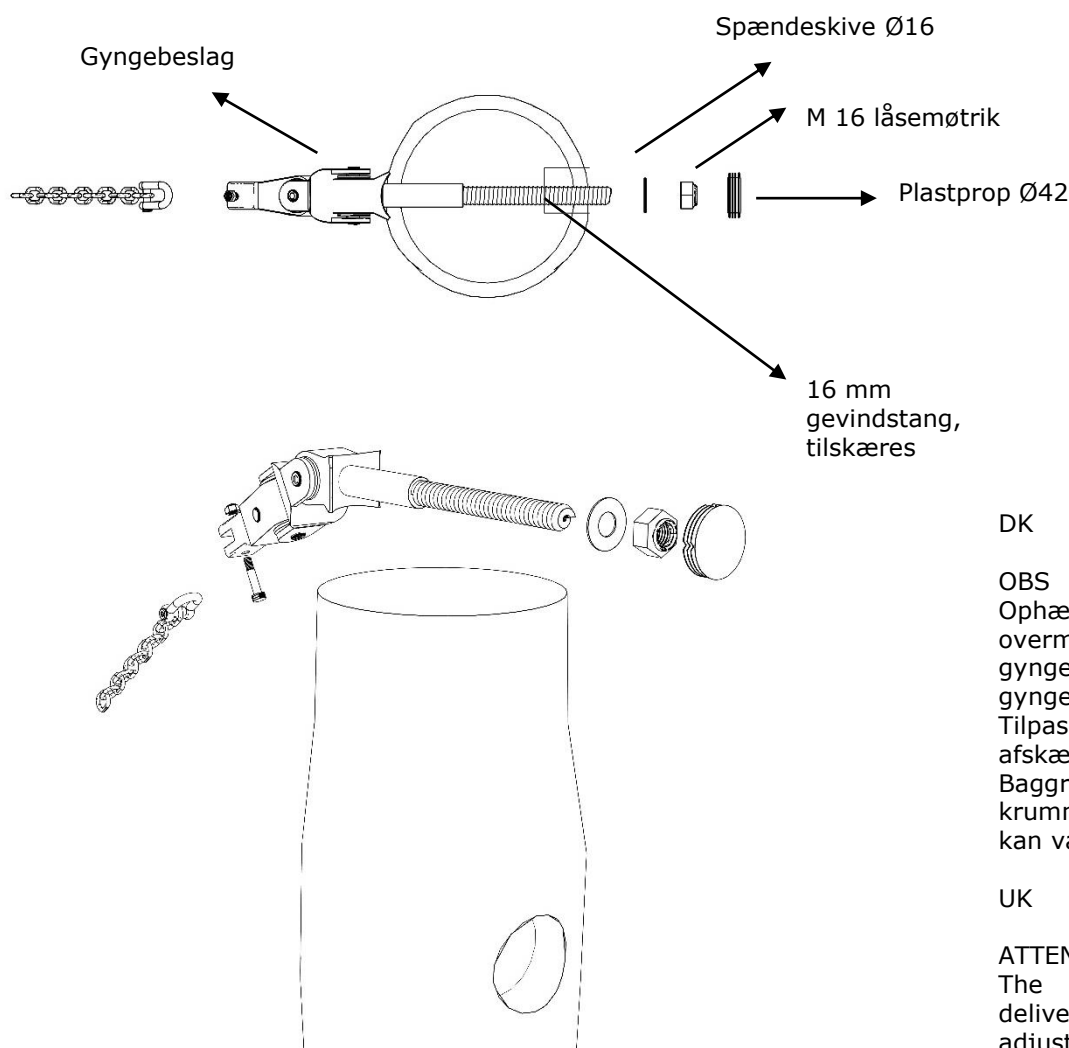

Montageprincip MP 06

DK

OBS

Ophængnings kæden leveres i overmål, og skal tilpasses så gynge er 40cm fra underkant gynge til færdigt underlag. Tilpasningen sker ved at afskærer overskydende kædeled. Baggrunden er at stolpernes krumning, diameter samt retning kan varierer.

UK

ATTENTION

The suspension chain is delivered in excess, and must be adjusted so that the swing is 40cm from the bottom edge of the swing to the finished surface. The adjustment is made by cutting off excess chain links. The background is that the curvature, diameter and direction of the posts can vary.

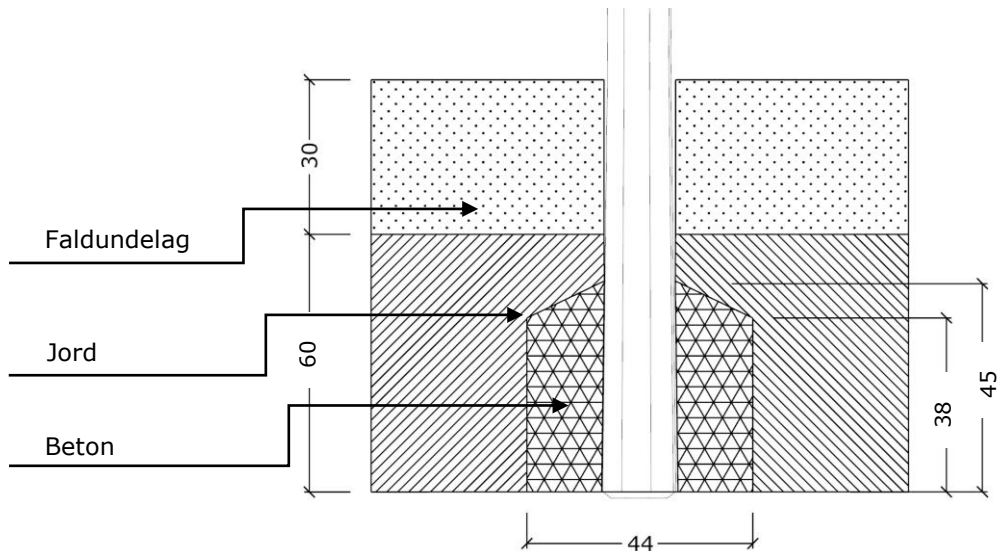

Fundering, FD F3